

Wood Stone



BISTRO 3030

Stone Hearth Cooking Appliance



Job Name	
Model	WS-BH-3030-RFG
Item#	
Fuel Type	Gas-Fired

The Bistro 3030 features a standard door opening 18.5 inches wide x 10 inches high. The cooking surface is 22 inches wide, and 19 inches deep, resulting in almost 3 square feet of usable deck space. It has a residential ETL listing for indoor or outdoor installations with a 1-inch side and back clearance to combustible building materials.

The oven sits on a heavy-duty frame. A stainless steel storage compartment or stainless drawers are an optional and can be provided in the support frame. The Bistro appliances come standard with a heat-up timer, enabling the cook to program the oven to turn on while they are out.

The dense, high temperature ceramic formulation of which the 175-pound, monolithic, cast-ceramic floor and the 335-pound, monolithic dome are cast creates a "deep heat sink" within the chamber of the appliance. The hearth and dome are connected by a carefully tensioned steel exoskeleton, which ensures structural integrity and long life.

The front, sides and back of the appliance body are enclosed with stainless steel. The appliance sits on a heavy-duty, black stand which acts as a support frame. A stainless steel storage compartment is optional and can be provided in the support frame.

The ceramic interior is heated by a powerful, adjustable radiant burner located in the back of the appliance chamber. The burner is controlled exclusively by the chef. The heat distribution in the appliance can be adjusted to meet the needs of a variety of menu items. The Bistro can be configured to burn either Natural Gas or Propane - gas type must be specified at time of order.

The Bistro 3030 is a gas only oven. Please see our other residential ovens for wood or combination fuel options. The oven arrives crated and ready for assembly. For ease of installation the oven can be turned on its back to fit through 32-inch openings.

The Bistro 3030 vents through an 8-inch O.D. flue collar located above the doorway. The appliance can be direct connected to a power-ventilated, grease-rated chimney or can be vented with a Listed Type 1 exhaust hood, or one constructed in accordance with NFPA 96 and all relevant local and national codes. The appliance must be vented in accordance with all relevant local and national codes, and in a manner acceptable to the authority having jurisdiction.

Hearth Capacity

8" pizzas	2
10" pizzas	2
12" pizzas	1

Assuming 5-minute cook times, the approximate maximum hourly production capacity can be calculated by multiplying the above numbers by 12.

OPTIONAL ACCESSORIES

- Stainless Steel Appliance Tool Set (with stainless steel hangers)
- Stack-Mounted Exhaust Fan
- Wood Stone also manufactures a full line of accessories for stone hearth cooking
- Heat Efficiency Door



An ongoing program of product improvement may require us to change specifications without notice.
Revised October 2009

WOOD STONE CORPORATION

1801 W. Bakerview Rd.
Bellingham, WA 98226 USA

Tel (800) 578-6836
Fax (360) 734-0223

info@woodstonehome.com or visit www.woodstonehome.com



BISTRO 3030

Stone Hearth Cooking Appliance

Model
WS-BH-3030-RFG

Front View

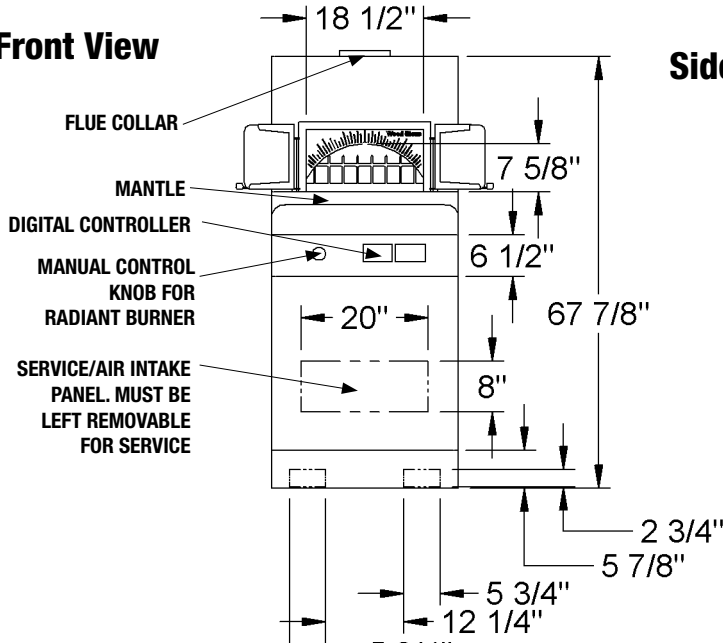

Side View

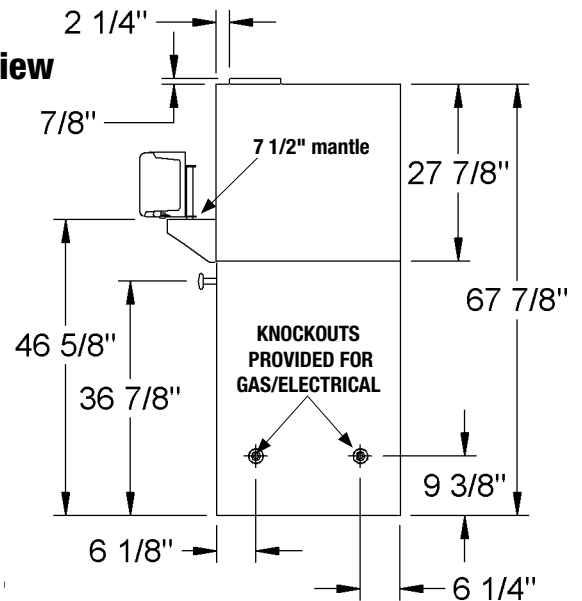

Rear View

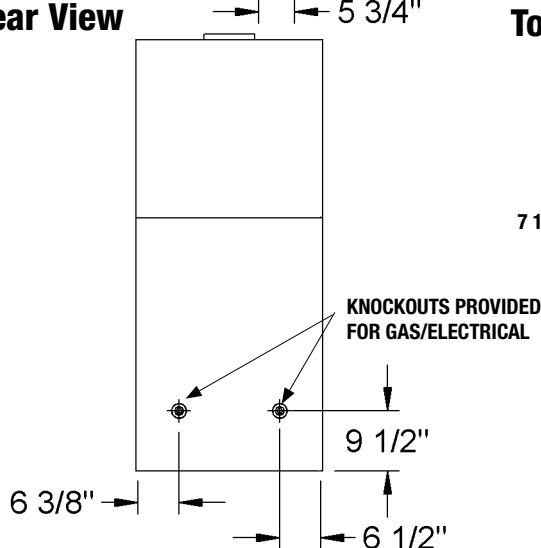

Top View

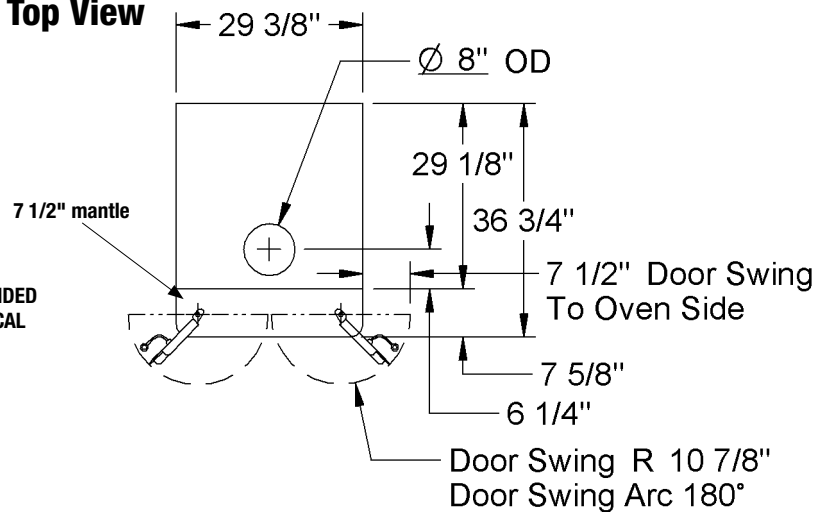

UTILITIES SPECIFICATIONS

Gas-3/4 inch FNPT gas inlet (female threaded) ♂

55,000 BTU Natural Gas Supply OR

42,000 BTU Propane (LP) Supply

**Unit Shipping Weight:
1100 lbs.**

Electrical

120 VAC, 2 amp, 50/60 Hz ⚡

All utility connections made on the back of the appliance control box. Remove front or rear panel for access, use utility knockouts (provided) to route gas and electrical supplies.

VENTING INFORMATION

The Bistro appliance can be direct connected to a power-ventilated, grease-rated chimney or can be vented with a Listed Type 1 exhaust hood, or one constructed in accordance with NFPA 96 and all relevant local and national codes. The appliance must be vented in accordance with all relevant local and national codes, and in a manner acceptable to the authority having jurisdiction.



Wood Stone

An ongoing program of product improvement may require us to change specifications without notice.
Revised October 2009

WOOD STONE CORPORATION

1801 W. Bakerview Rd.

Bellingham, WA 98226 USA

Tel (800) 578-6836

Fax (360) 734-0223

info@woodstonehome.com or visit www.woodstonehome.com