

Wood Stone

Job Name	
Model	WS-TL-AD
Item#	

DOUBLE COMPARTMENT ASH DISPOSAL DOLLY

The Wood Stone Double Compartment Ash Dolly is an efficient and safe means to store and transport the ash that needs to be removed from the oven each morning. It has two compartment sleeves for ash storage. After the first sleeve has been filled, the second sleeve should be filled. By the time the second sleeve has been filled, the first will have had time to cool and should be safe to dump. By separation of the ash into two compartments, it is easier to control the disposal of leftover ash in a safe manner.

Caution is necessary to prevent any live coals mixed in with the ash from being dumped into an area or container with combustibles. ALL ASH AND COALS SHOULD BE DOUSED WITH WATER AND EXTINGUISHED BEFORE FINAL DISPOSAL.

The unit comes with a lock eye, and a brass security lock with two keys. The unit is made of 16-gauge stainless steel with a non-marking perimeter bumper edge. It has four non-marking, fully revolving low profile casters.

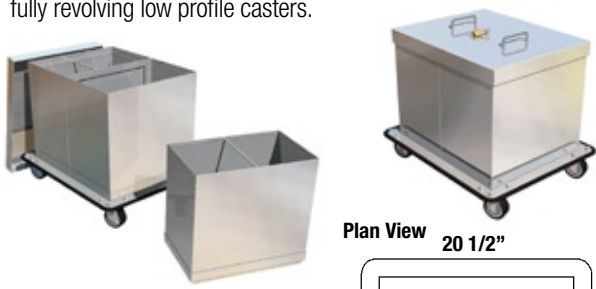

Unit Weight: 75 lbs.
Minimum Shipping Weight: 150 lbs.

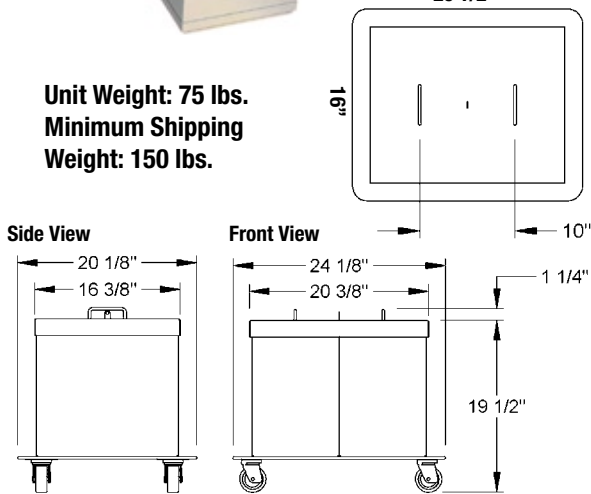

WOOD CART ASH DISPOSAL DOLLY



Job Name	
Model	WS-TL-WHC
Item#	

WOOD HANDLING ACCESSORIES

Wood Stone's stainless steel wood handling cart is designed to address the day-to-day issues of getting fuel from the main wood storage area to the solid fuel appliance. The 6.5-cubic-foot capacity cart is constructed from 14-gauge stainless steel. The cart is designed to hold 18 inch logs and to contain the accompanying bark chips and sawdust. It rolls easily over thresholds and carpeting on durable, 3 inch x 7/8 inch, fully revolving, non-marking casters. This piece is built for a lifetime of reliable use.

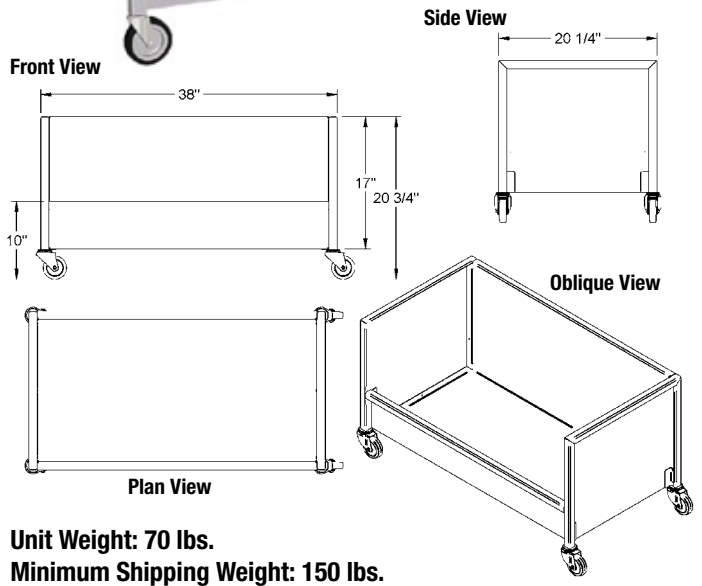

An ongoing program of product improvement may require us to change specifications without notice.
Revised October 2009

WOOD STONE CORPORATION
1801 W. Bakerview Rd.
Bellingham, WA 98226 USA

Toll Free (800) 578-6836
Tel (360) 650-1111
Fax (360) 734-0223

info@woodstonehome.com or visit www.woodstonehome.com